

2011 LIGHTNING ROD SPECIFICATIONS

VIOLATIONS

When referring to the engine, gearbox, differential, mechanical or construction, rules and regulations the principle will always be: Unless permission is specifically granted to make modifications, or any variation, nothing may be done to alter or change in any way the standard Parts.

Unless these rules state you can do it, you **CANNOT DO IT**.

Cars, Engines and Fuel will be checked on a random basis.

Violations will result in an immediate suspension of all racing facilities and any refusal will also result in an immediate suspension.

All car and engine specifications will be taken from the Technical Service Data book for cars as published by Glass's Guide Service Limited. Technical queries can be addressed to, The Secretary, ORCi Limited, Technical Committee, P.O.Box 9889, Birmingham, B43 6WA.

Drivers are reminded that scrutineering checks can be carried out at any time, and most certainly at official championships. If parts are suspected of being illegal make sure you leave them with the promotion if you do not agree. If you refuse it will automatically make the parts illegal. **It is the responsibility of the driver to prove to the promotion that the part is legal by the way of written proof of where the part originated. This must be done within seven days, otherwise the part(s) in question will be deemed to be illegal and will result in immediate suspension from racing and referral for disciplinary action.**

CARS

Only right hand drive Ford Sierra hatchback or saloon cars are permitted. Only one driver per car and one car per driver is permitted at each meeting.

Please note : Applications to the ORCi Limited for proposals for alternative/future types of cars are welcomed. These will be considered by the Technical Committee and may result in an Experimental licence being granted for the 2011 season for the car to be run.

1. ENGINE

The Ford 2 litre Pinto engine must be in standard form but may have a modified camshaft and may be prepared to the following specifications:

- a) Nominal bore size 90.84mm plus 1.5mm oversize. Standard stroke 76.95mm.
- b) Block and head may be skimmed but the pistons may not protrude above the block. Pistons may not be skimmed or modified in any way. A standard crankshaft must be used.
- c) Engine balancing : CRANKSHAFT – spot machining only; CON RODS – Spot machining only on the counter weight balance pad area at the big and small end. ONE con rod must remain original and untouched. Con rod bolts may be changed but con rods must not be drilled or modified to accept them; PISTONS – Spot machining only and one piston must be original and untouched. All four pistons must have original marking on crown. NOTE: Spot machining means you can either hand grind, drill or machine.
- d) Only standard pistons or standard replacement pistons (i.e. KS Karl Schmidt, Mahle, Hepolite/Wellworthy AE) may be used. Any make of piston ring may be used providing the number of rings remains the same as standard and no machining of the pistons or rings other than gapping is required. No forged pistons are allowed. (See 2c for balancing).
- e) Camshafts are free, vernier cam wheels may be used and any single valve spring may be used that fits without any modification to the standard spring tops. Extended ball studs are permitted. Rocker arms are free with the exception or roller rockers. Heavy-duty valve retaining caps are permitted for use. Camshaft centre main bearing caps may be strapped.
- f) Head: You may use any standard 2 litre S.O.H.C. Sierra/Pinto head. No modification is allowed except valve spring seats may be machined. Valves must be standard and of standard Ford length. N.B. On Standard Ford Inlet Valves only, where the back of the valve meets the valve seat, there may be a slight lip, this may be ground away at a 30° angle, to a maximum width of 2.5mm. Over size valve stems are allowed, and valve seats may be re-cut. A three angle valve seat may be used to the following specification: Angle 1 – Combustion Chamber 30°, Angle 2 – Valve Seat 45°, Angle 3 – Port 60° - 65°, with valve seat width free. No gas flowing or adding of material to the ports or combustion chamber. Replacement valve guides may be used but must use original position. Bronze valve guides are not permitted, but thin wall bronze inserts may be used.
- g) Flywheel and Clutch: Any standard Pinto engine flywheel may be used which may be lightened. Only the standard type clutch may be used. Flywheels **MUST** be dowelled to the crank. **An ORCi approved steel flywheel is available from Turbosport. Contact 01489 406886.**
- h) No competition gaskets allowed. Only Ford, Payen or standard American version may be used.
- i) Standard Motorcraft or Bosch distributors must be used with either points and condenser or electronic ignition. * See rule 14. The mechanical advance may be altered, and the vacuum advance may be altered or removed.
- j) Engine Mounts: Engine mounting brackets must remain standard, but the mounting may be modified. The engine must occupy its original position. The charging system: Power steering pumps may be removed, fan belts are free but standard pulleys must be used. Blocks may be rebored to size, sleeved, line bored and surface ground.

No other modifications are allowed. Sumps: No alloy sumps. Standard steel sumps must be used. Pick up pipes may be modified and sumps may be baffled. No outside alterations may be made.

- k) Oil coolers may be fitted using a sandwich plate between the oil filter and block. Oil coolers must be fitted within the engine compartment. No remote oil filters.
- l) The engine must be fitted with a metal catch tank of 1 litre minimum capacity. It must have a minimum of 2 breather pipes connected to it, one from the rocker box and one from the crankcase. The only modification allowed to the rocker cover is for breathing purposes only.
- m) No turbos, no fuel injection, no forced induction of any kind.
- n) The exhaust manifold must be in standard form and standard to the Sierra/Pinto 2 litre. The inlet manifold must be standard with the exception of water circulation holes, which may be blanked off.
- o) All engine parts not mentioned above must remain standard.
- p) Water cooling systems may be modified, provided that all modifications are inside the original bonnet outline.
- q) **Cables are free.**

Please note : Applications to the ORCi Limited for proposals for alternative/future types of engines in conjunction with an alternative body-shell are also welcomed. These will be considered by the Technical Committee and may result in an Experimental licence being granted for the 2011 season for the car to be run.

2. EXHAUST SYSTEM

The standard exhaust system may be retained, or AX891, Laws or Simpson ORC225. A minimum of 2" (50mm) and a maximum of 10" (254mm) section of tail pipe must be fitted to the silencer facing rearwards or down - THIS WILL BE MEASURED FROM THE REAR OF THE BOX (NOT THE PIPE). The front downpipe must remain standard; you may weld a maximum 1½" (38mm) plate in between 2 downtubes to stop them breaking off and you may, at the bottom of the downpipe, fit a fuel mixing sensor the front downpipe can only be modified at the tail end to allow the exhaust to run through the car, by shortening by up to 1". If this modification is made, the joining pipe must either fit inside the front pipe or it may be butt-welded to the front pipe. The flange may be removed. If exhaust systems pass through the car they must be covered. If a silencer becomes ineffective during racing or practice, the car will be withdrawn from the event. Exhaust must terminate towards the rear of the car and may not terminate through the side of the car.

4. CARBURETTOR & INLET MANIFOLD

Only the standard Weber 32/36 DGV or DGVA carburettor may be used with a maximum of 26mm and a 27mm sized chokes. No polishing or re-profiling is allowed. No modifications to the carburettors body or original design. **The interchanging of the carburettor top from other Weber models is not allowed.** All gaskets must remain standard and original. A single original spec insulator block must be fitted between carburettor and inlet manifold, with two gaskets; approximate total thickness = 5mm. Main jets, primary and secondary jets, auxiliary venturi and emulsion tubes may be changed but must face downwards towards the butterflies. Accelerator pump jets may be changed but face downwards towards butterflies. Chokes may be modified to open together and replacement spindles may be fitted with standard screws. Cold starting devices may be removed with retaining lugs and subsequent holes blanked off. Air and fuel galleries may not be enlarged or modified, and fuel may enter on either side. Floats may not be modified or weighted, and must control the fuel flow. Needle valves may not be larger than 250, and not enlarged or modified. The power valve must be fitted in the base of the bowl, but may be sealed off, and the diaphragm may be removed. No trumpets are allowed. It is permitted to use a grub screw or similar device to fix the auxiliary venturi to the carburettor body. Top end enrichment devices may **not** be blanked off or modified. A secondary fixing on the fuel inlet feed line is required. The Inlet manifold must be standard & not faced to alter the angle of the manifold to the carburettor. No inlet port matching of the carburettor to the manifold or the manifold to the head. No material may be added or removed from the gas flow area, it must be as standard.

5. GEARBOX & DIFFERENTIALS

Must be standard to the range and fitted by the manufacturer with the exception that the P100/Ford Cortina gearbox may be fitted into the Sierra. All gearboxes must have a conventional type bell housing and the gear change must require a clutch and must be operated by a lever arm. No competition type gearboxes allowed. No aluminium bell housings allowed. Differential ratios are free and may be locked by welding only. No limited slip differentials, no Cosworth, XR4 or 4 x 4 parts to be used. No torque biasing assemblies. Axle and diff must remain the same concept as original. Propshaft is free. Gear sticks are free. The differential must not be moved in any way from its original position.

6. FRONT SUSPENSION

Positive camber on the offside front wheel is allowed, this can only be achieved by the drilling of the cross member only and the offside bottom arm must remain standard length, the anti-roll bar may be modified to suit. Negative camber on the nearside front wheel is permitted but not adjustable. This may be achieved by re-drilling the cross member AND lengthening the nearside bottom arm by a maximum of 2", the roll bar may be modified accordingly. Anti-roll bars may be modified to suit. Lengthening must not be achieved with threaded bar. Positive camber on the O/S front wheel is allowed. The springs are free and the car may be lowered. All suspension parts must be located by original mounting points on the chassis and body, with the exception of front bottom arms. Solid bushes are allowed but not competition or Cosworth type. Poly bushes are not allowed. The exception to this is that you may re-drill a maximum of two extra holes (one on each side) in the front cross member bottom arm location. Strut braces may only be fitted on the front struts and may be triangular shape and bolted to the bulkhead only not the roll cage. Top

mounting plate may be modified to locate 2¼" springs. Dampers may be up-rated, the Leda leg with non standard spring platform & the Gaz equivalent may be used, but no metal must be added to them.

7. REAR SUSPENSION

The components are to be standard & original in length. No adjustable parts or modifications are allowed. Only standard bushes are permitted, no competition parts. Suspension may be lowered. Springs are free. Positive or negative camber may only be achieved by shimming the drive shaft location. No rear Steer. Top spring cups may be modified to take 2¼" springs.

8. STEERING

The Steering rack must occupy its original position, & manual racks can replace PAS systems. Quick racks can also be used. The steering rack arms may be modified: Nearside rack arm may be lengthened, the Offside may be shortened. The steering column height may be adjusted & reinforced at the top bracket. A quick release steering wheel is recommended.

9. WHEELS AND TYRES

Any steel or alloy wheel can be used to a maximum of 7". Wheel studs are free. No wheel spacers allowed, whether welded to the wheel or not, unless fitted as standard. The only tyre permitted is the Yokohama 185 / 70 x 13 A021R, compound No.T567. Tyre gaiters are not permitted. No alteration can be made to the original tread pattern by tyre cutting.

10. BRAKES

To be original and to work on all wheels. Handbrake is compulsory. No biased braking. No ABS, no 4 x 4 or Cosworth parts allowed. Brake pipes may be allowed to pass through the car. The use of competition brake pads is permitted, however, the use of competition brake pipes is not allowed.

11. BODYWORK

To remain standard including floor pan with removal of inner door panels permitted but any removal of structural stiffeners is not permitted, with the exception of the bonnet and boot stiffeners. No holes are allowed in any panel, other than original. On two door shells, the inner skin may be removed between the B and C posts below the waistline of the car. No armouring whatsoever. All doors must be fixed closed when racing. No spoilers or aerofoils unless fitted as standard to the range of car. No roof pods or fins. Grilles must remain in their original position. Replacement grilles must be made of plastic. Fibreglass grilles are allowed and may include headlamp apertures. Front and rear light apertures may be blanked using a maximum thickness of 2mm aluminium and must not overlap apertures by more than 25mm. Headlamps may be blanked on the front or back of the apertures. All flammable material must be removed. Any replacement dashboards for gauges etc. must be made of aluminium. Wheel arches may be relieved to a maximum of 2" but the original shape must be retained. They may be re-welded, but no adding of extra metal and no sharp edges should remain. A metal upright ¾" x ¾" must be welded or bolted into the windscreen aperture, one third of the way along the driver's side. Plastic bumpers must remain in place with the exception of the rear bumper which may be replaced with an approved metal bumper manufactured by Davies Preparations Tel 01474 355332 (workshop) or 01474 332240 (home). In addition Rover 400 Series/Rover 45 or Ford Escort Mk V bumpers may be used as replacements. Additional means of fixing are allowed, but these must not be used as armouring. All fixing bolts must be the coach bolt type with the head of the bolt facing outwards. Standard lifting/towing eyes must be retained. No foam filled panels are allowed. Fabricated doors including the rear quarter are allowed, but must be of professional appearance; the maximum thickness of steel sheet used must be 1mm. There must be no overlapping and should be no thicker than original. Fibre Glass Front/Rear bumpers are permitted and should consist of a maximum of three layers, one of which may be KEVLAR. The total maximum bumper thickness allowed is 10mm. The circular area of the spare wheel carrier may be removed but must be replaced with a steel plate of equal thickness to the original metal – You may not remove any other sections of the boot floor.

12. ROLL CAGES

The minimum requirement is a four post roll cage with down bars in support of the A & B posts, constructed from mild steel members, minimum size of 32mm x 32mm x 3mm, or 38mm x 38mm x 2.5mm box or tube, all securely welded at all joints as shown and must include the following.

A 230 mm square plate, minimum 3mm thick, welded between the base of the uprights and the floor for additional strength

1. One horizontal bar between A Posts (at dashboard level)
2. One horizontal bar between B posts at approximately mid height and adapted to form support to the seat / seat headrest or a seat hoop.
3. Two "chicken" bars in the drivers door aperture and two in the passenger door aperture. Chicken bars to fit between A & B post support down bars and no further. Bars that lay on the sills will not be classed as chicken bars.
4. Two down bars, one each side from the roll cage top, to either, the rear suspension turret (5) or (5A) into the boot well, terminating 100mm short of the back panel.

The following members may be added (to the same material specification as the roll cage) :

- 6. Two bars, one each side, from the B post down bar base, rearward to the suspension turret.

ROLL CAGE DIAGRAMS

MINIMUM SPECIFICATION ROLL CAGE

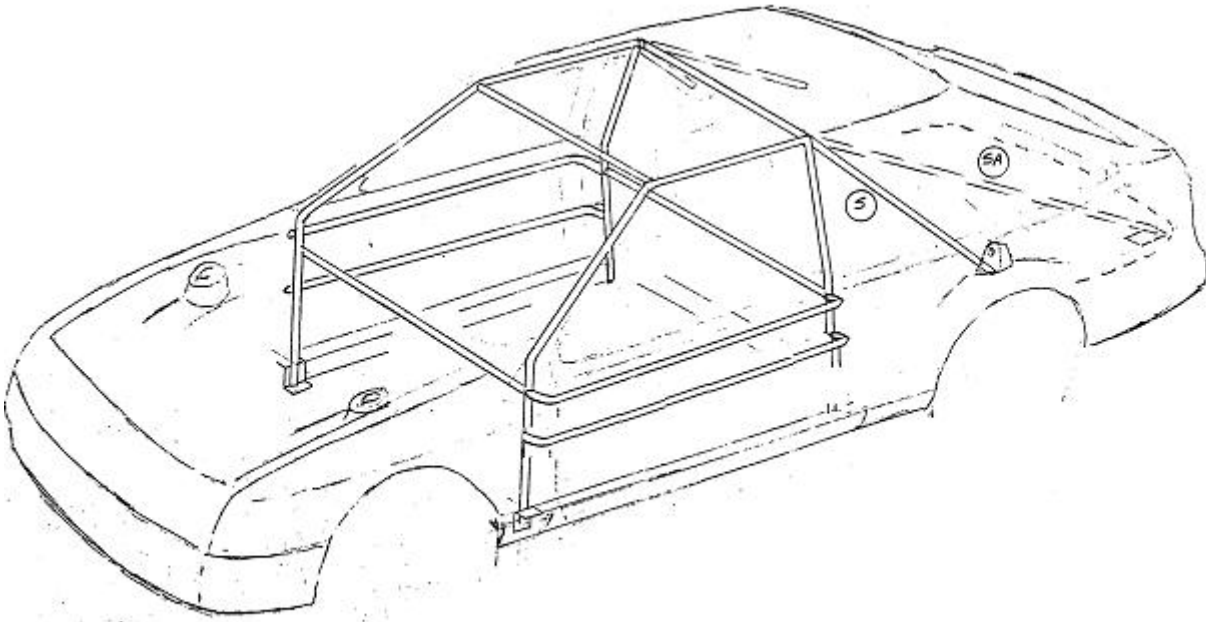

MAXIMUM SPECIFICATION ROLL CAGE

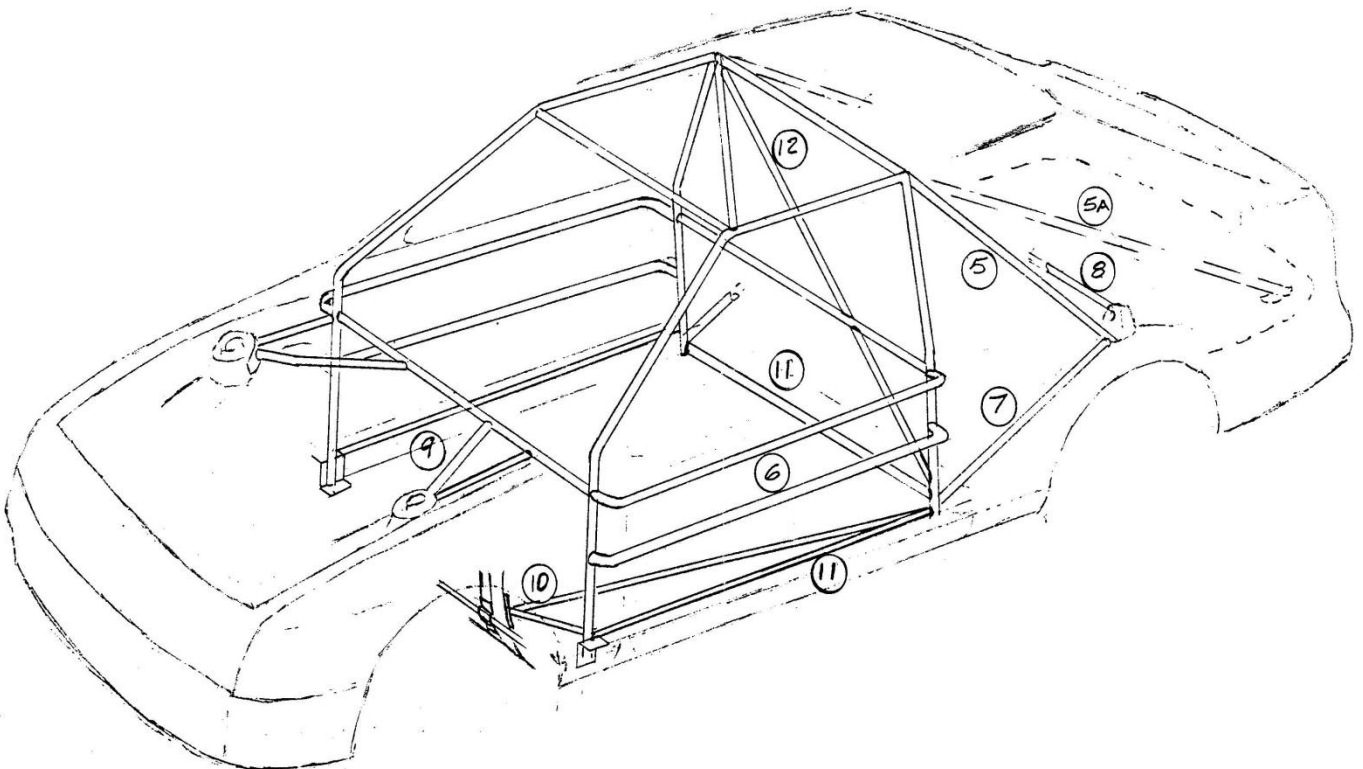

- 7. A cross bar fitted across the rear suspension turrets, this may be cranked and welded to the floor panel in a central location.

8. Members may be positioned from the roll cage, forward through the bulkhead and connected to the front suspension turrets. Members must be within the engine bay aperture and horizontal (within practical limits)
9. Additional bars in passenger side to support front roll bar, rear mounting area (in the footwell). Bars must be positioned low down such that access to the driver is not limited.
10. One horizontal bar each side between A & B post support down bars at sill height and between B posts (to protect legs/feet in a side impact situation).
11. One diagonal member between either B post support uprights or rearward members described in (5)

Further Notes

No suspension components may be fixed directly to roll cage / support members.

All members must be positioned within the body lines and fitted as supports/protection NOT armouring.

No other members must be added as the list above describes the full limit of roll cage construction that is allowed.

Please refer to the roll cage diagrams which illustrate the minimum required and the maximum allowed.

13. SCREEN

All glass must be removed. Front screen must have a central bar of 19mm x19mm or 3/4" x 3/4" SHS welded in place. An interior mirror must be fitted. A drivers door mirror must be fitted, mounted in such a position that it does not project further out than the body. (Must not be able to get knocked off whist in racing traffic)

14. STOP LIGHTS

Either two stop/brake lights or one single stop/brake strip-light must be fitted facing rearwards. If two lights, they must be a minimum of 30 inches (762 mm) apart. Lamp(s) must be operated by the standard stop light switch as fitted to the particular model of car. No other switches or modifications to switches to be made. Bulbs to be of 21 watt intensity. For round type lamps: minimum diameter 3" (76mm), maximum diameter 5" (127mm). For square/rectangular type lamps: minimum 3" (76mm) square, maximum 5" (127mm) square. For strip type lamps, minimum of 8" (203mm), maximum of 16" (406mm) width and should be fitted securely to allow a clear view from the rear. All bulbs must be working.

15. SEATS

You must have a Competition type Driving Seat with a head restraint.

The seat should occupy its original position where possible and be suitably supported at shoulder height and on both of the sides and back, with a suitable framework or seat stiffener's.

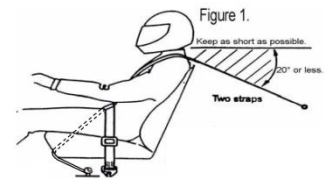

16. BATTERIES & ELECTRICAL

May be brought inside the car, but the floor must not be cut to accommodate the battery. They must be firmly fixed and covered with a material which will not rot due to acid contamination. Contact between the safety harness and batteries must not be possible. Batteries must be a minimum of 6" (152mm) from fuel tank. An electrical cut off switch must be fitted to the R/N/S corner of the car. If Lumination is used they must be of the following part nos: Ford: Bosch fitting kit FK221 power module PMA50, Motorcraft FK9 PMA50. A 24 volt starter system is permitted.

17. NUMBERS

The driver's racing number must appear on the doors of the car. They should be preferably in large American style numbers on a contrasting background. The bigger the better. You should also paint your number in black on white or white on black in the rear corner of your roof to assist with lap scoring at tracks with race controls that are located in a high position. A 'Sun Visor' made of metal and having a depth of at least 6" must be fitted to the top of the windscreen aperture when no laminated glass or perspex is fitted. The drivers name only must appear across the sun visor position. All signwriting must have a professional appearance.

Scrutineers will instruct drivers to change their numbers if lap scorers find it difficult to read them. The whole of the roof of the car (with the exception of number triangle) must be painted in the drivers current grade colour.

World Champion.....	Gold Roof
European Champion.....	Red and Yellow Chequered
British Champion.....	Black and White Chequered
English Champion.....	White with Red Cross
National Champion.....	Gold Stripe
Points Champion.....	Silver Roof

If you win a race at a meeting; you will start the remaining races from the rear of your grade. Should you win another race at the same meeting – you will be automatically upgraded.

18 FUEL SYSTEM

Fuel tanks must be metal or FIA approved with a maximum capacity of 4 gallons or less are permitted. These must be fitted rear of the driver but in front of the rear axle centre line, i.e. they are no longer allowed to be fitted in the boot area. They MUST NOT BE FITTED BELOW THE CHASSIS RAILS of the car, and the floor must not be cut in any

way to accept the tank. All tank filler caps must be of a secure leak proof metal or screw fitting. Petrol pipes must be of metal or metal covered and have a shut off tap within easy reach of the driver. All tanks must be fitted with a breather system which prevents spillage if a car is inverted. The fuel tank must be a minimum of 6" (152mm) from the battery. All petrol pick up pipes must draw through a stand pipe from the top of the fuel tank. Four 2" holes must be drilled at the lowest point under tanks to allow spilled petrol to drain. A firewall between fuel tank including filler cap/pump and driver must be fitted. Fuel regulators may be used.

19 FUEL

For the full fuel specification please see back page.

20. WEIGHT

Warning : Cars can be weighed at any time before, during or after a meeting, without driver. They must always achieve the minimum weight; the adding of fuel or any other liquids is not allowed to achieve this minimum weight. The minimum car weight is 845Kg. The use of ballast to achieve this weight must be steel plate bolted to the floor. The internal plating must be of equal proportions on both sides and front to rear of the car both in construction and gauge. I.E. If a 10Kg weight is fitted in the front offside foot well, a 10 Kg weight must also be fitted in the nearside foot well. Bolts of the same size and material must be used to fit the plates and the bolts must be welded.

21. TRANSPONDERS

Transponders are mandatory and should be working at all times. They should be fitted 1.8 metres back from the front most position of the car. A hole of at least 6" (150mm) square is required in the floor, with the transponder fitted vertically, just below the hole. In the event of a dispute with the transponder result, the Steward of the meeting will make the final decision. Any driver found to have fitted the transponder further forward than the required 1.8 metres will be excluded up from the meeting.

22. SAFETY EQUIPMENT

- ***Helmets must be of a minimum standard as directed by British Oval Racing Safety Executive (B.O.R.S.E). These are BS6658 Type A/FR, FIA8860-2004, Snell SA2005, Snell SA2010, SFI Foundation 31.1A, SFI Foundation 31.2A. The E2205 European standard helmet may be used in Fibreglass, Carbon or Tri-Composite form only i.e. NO POLYCARBONATE helmets are allowed. It is important that the helmet fits the driver correctly. Shatterproof goggles/visors must be worn although tinted visors are not advisable. Your helmet must display the current ORCi (ORC10) sticker.***
- Neck braces are recommended.
- Fireproof balaclavas are **MANDATORY** and must be marked appropriately.
- Fire retardant gloves are **MANDATORY** and must be marked appropriately. Drivers must wear bright coloured racing overall type clothing of flame retardant Proban or a high specification material and this must be maintained in a clean and tidy condition in view of the public. N.B. If wet weather clothing is used this must be worn IN ADDITION TO and NOT INSTEAD OF the regulation flame retardant overall type of clothing described above.
- A quick release cloth window net must be fitted to the driver's door window aperture. The netting should have holes not larger than 7.5cm or 3" wide. It should come down level with the steering wheel, and should be flexible and easily removable separate to the movement of the door.
- A 1Kg Dry Powder Gauge Fire Extinguisher is highly recommended and if fitted, this should be in a tube with a spring top and should be within easy reach of the driver. Old type BCF (green) type extinguishers are not allowed. All tow vehicles, must carry a minimum of a 2kg fire extinguisher dry powder or gas, which must be within easy reach of the driver and mechanics at all times, especially when refueling.
- A minimum of 3" (75mm) wide safety belts (1.75" (40mm) sub-strap) are mandatory. This must be a full five point buckle release harness (including NASCAR type) with sub-strap and must be fitted and bolted to the floor and/or the roll cage. Shoulder belts with a sternum protection latch are highly recommended. The sub-strap must be used at all times and all belts must connect to the quick release buckle. In the case of NASCAR lever latch buckles it is advisable to fit a secondary means of detent to prevent overall sleeves accidentally unhooking buckles during racing. A small section of Tubegrip elasticated bandage slid over the hooked buckle serves this purpose. Special attention must be paid to the condition of seat belts and fixings once fitted. An extra bar is to be fitted to roll cage behind drivers seat approx 4" below shoulder height of driver. Your seat belts may be fixed to this bar. The bar is to be of roll cage material specification.

Following recent research made by leading safety harness manufacturers, new information has been made available with regard to the best way to fit your safety harness, which will further ensure your safety. Please study the diagrams below to ensure your safety harness is fitted correctly.

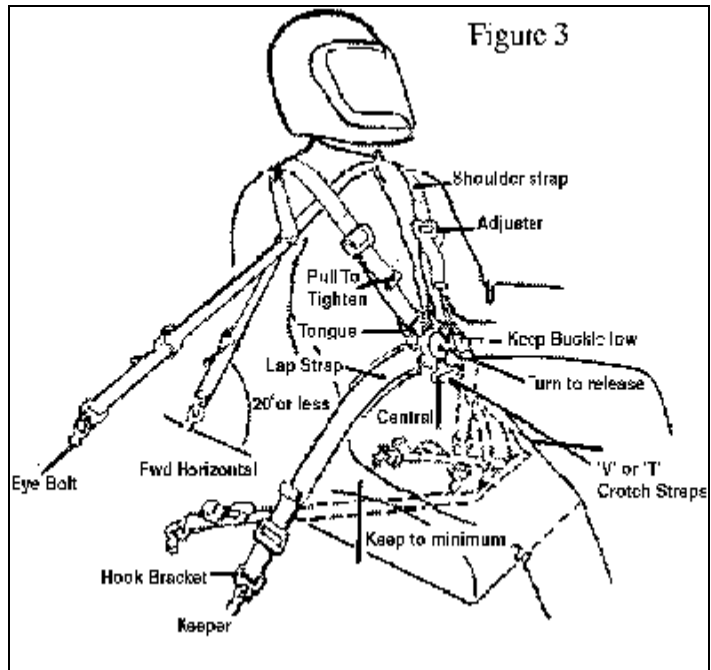
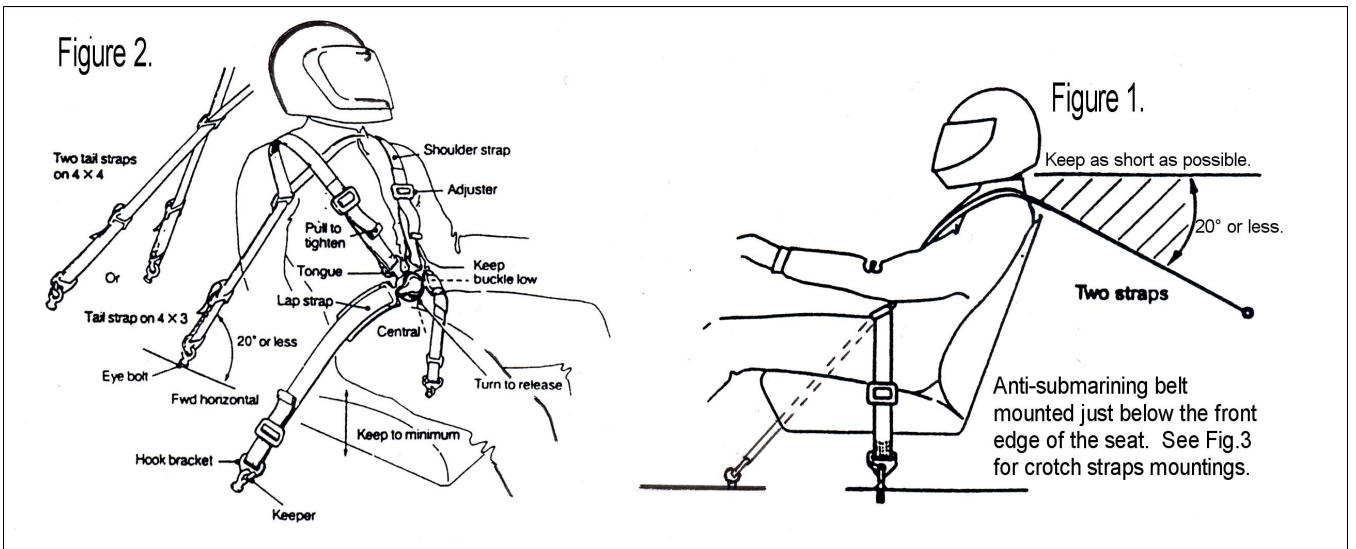

Please note that all of the above rules are subject to change in respect of Health & Safety requirements.

REVISED RULES FOR 2011 IN BOLD/ITALIC PRINT.

ITEMS MARKED STRIKETHROUGH ARE NO LONGER ALLOWED

2011 Lightning Rod Technical Specifications Issue 1, Dated 28th November 2010.

All Oval Racing Formulae

Permitted fuel specification from 1st January 2008 (this specification supersedes all previous specs).

1. All cars must only use fuel from roadside pumps as defined below.
Petrol (Motor Gasoline of the type on sale to the general public from roadside filling stations) BS 4040 (Leaded) Subject to a valid permit for use. LRG (Unleaded), BS EN 228 (Unleaded), BS7800 (Super Unleaded).
2. Petrol is a product refined from crude oil that contains a large number of identifiable compounds that can typically be 250 in number. These compounds can be identified and compared to the available petrol from major oil companies and suppliers.
3. Unless otherwise stated, or the distinction is made between leaded and unleaded petrol, major gasoline fuel shall meet the following; Acceptance levels for Octane numbers will be determined at 95% confidence level. Only additives to this motor gasoline fuel solely for the purpose of lead replacement are allowed.
4. Lead Replacement Gasoline, LRG, also known as LRP. Only additives from Sodium, Phosphorous, Potassium, or Manganese according to manufacturers recommendations are allowed. Note; Manganese can enhance octane values in any petrol. Under no circumstances will values in excess of 0.005 grams/litre be permitted.
Lead in excess of EU directive 98/70EC requirements is illegal.
5. We reserve the right to amend the detail of the above specification to reflect any change occurring in the quality of the fuel on sale to the general public at any time.

Roadside fuel consistency when testing fuel samples.

	BS EN 228	BS 7800	BS 4040	LRG/LRP	Test Standard
Motor Oct No (max)	89.0	89.0	89.0	89.0	ASTM D2700/86
Mon (min)	85.0	86.0	86.0	86.0	ASTM D2700/86
Research Oct No (max)	100.0	100.0	100.0	100.0	ASTM D2699/86
Ron (min)	95.0	97.0	97.0	97.0	ASTM D2699/86
Lead (max)	0.005	0.005	0.15		ASTM D3341 / IP362
Lead (min)	ASTM D3237	ASTM D3237		0.005	ASTM D3237 / D3341 / IP362
Density @ 15°	0.720 - 0.775	0.720 - 0.775	0.720 - 0.775	0.720 - 0.775	ASTM D1298/ D4052
Oxygen % max	2.7% w/w	2.7% w/w	2.7% w/w	2.7% w/w	Elemental
Nitrogen % max	0.1% w/w	0.1% w/w	0.1% w/w	0.1% w/w	ASTM D4629/ IP379
Benzene % max	1.0% v/v	1.0% v/v	1.0% v/v	1.0% v/v	EN238
Sulphur	150mg/kg	150mg/kg	150mg/kg	150mg/kg	EN ISO 14596 / ASTM D2622
Olefins*	18% v/v	18% v/v	18% v/v	18% v/v	ASTM D1319
Aromatics*	42% v/v	42% v/v	42% v/v	42% v/v	ASTM D1319

* Olefins and Aromatics values are expressed as a percentage of total fuel.